

UNIVERSITY OF CALIFORNIA, SANTA BARBARA

BERKELEY • DAVIS • IRVINE • LOS ANGELES • MERCED • RIVERSIDE • SAN DIEGO • SAN FRANCISCO



SANTA BARBARA • SANTA CRUZ

OFFICE OF DESIGN & CONSTRUCTION SERVICES and PHYSICAL FACILITIES

CONTRACTING SERVICES
Building 439
Santa Barbara, California 93106-1030
Telephone (805) 893-3356
Fax (805) 893-8592

- SENT VIA:** FAX ON THIS DATE
 HAND DELIVERY ON THIS DATE
 FEDERAL EXPRESS ON THIS DATE
 UNITED PARCEL SERVICE ON THIS DATE

HOLDERS OF PLANS AND SPECIFICATIONS:

Anacapa Residence Hall Fire Safety and Renewal,
Bldg 547
Project No. FM130245L/988650
Addendum No. 2

April 11, 2013

Enclosed is **ADDENDUM NO. 2** to the Construction Documents on the above-captioned project.

Bid Date: Tuesday, April 16, 2013 at 2:30 PM to be held at:

CONTRACTING SERVICES
Facilities Management, Bldg. 439,
Door #E, Reception Counter
University of California, Santa Barbara
Santa Barbara, CA 93106-1030.

Late arrivals shall be disqualified. Please allow time for unforeseen traffic delays, securing a parking permit and potential parking problems.

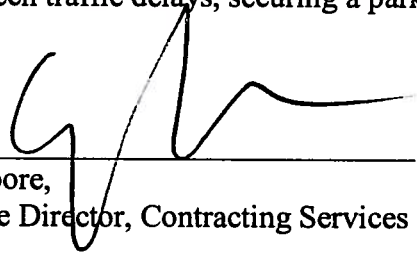

Greg Moore,
Associate Director, Contracting Services

ADDENDUM NO. 2

to the

CONSTRUCTION DOCUMENTS

April 11, 2013

The following changes, additions or deletions shall be made to the following documents(s) as indicated; all other conditions shall remain the same.

I. SPECIFICATIONS:

Item No.

1. SPECIFICATION SECTION 01026 – UNIT PRICING:

REVISE paragraph 2.01, Unit Price No. 1.A to read:

“A. For the cost to furnish and install an estimated quantity of 200 square feet of student room stretched fabric wall system, including new frame, core material and fabric over existing fabric wrapped gypsum board for up to 100 rooms, as specified in Section 09772- STRETCHED FABRIC WALL SYSTEMS.”

2. SPECIFICATION SECTION 01852 – LEED REQUIREMENTS:

DELETE the following sentence from 2.5.B:

“B. Credit IEQ4.2: For field applications that are inside the weatherproofing system, paints and coatings shall comply with the following VOC content limits when calculated according to 40 CFR 59, Subpart D (EPA Method 24).”

And **REPLACE** in its entirety with the following:

“B. Credit IEQ4.2: For field applications that are inside the weatherproofing system, paints and coatings shall comply with the following VOC content limits:”

**All other portions of 2.5B shall remain the same.

3. SPECIFICATION SECTION 06202 – INTERIOR FINISH CARPENTRY:

ADD paragraph 1.2.A.3 as follows:

“3. Wood base at CMU walls where indicated on drawings.”

4. SPECIFICATION SECTION 06402 – INTERIOR ARCHITECTURAL WOODWORK: **REVISE** paragraph 1.4.E.1 to read:

- “1. Product Data for Credit IEQ 4.1: For installation adhesives, including printed statement of VOC content not to exceed 30 g/L.”

5. SPECIFICATION SECTION 08411 – ALUMINUM FRAMED ENTRANCES AND STOREFRONTS: **ADD** paragraph 1.3.A.2 as follows:

- “2. Product Data for Credit MR4: For products having recycled content, documentation indicating percentages by weight of post consumer and preconsumer recycled content. Include statement indicating cost for each product having recycled content.”

6. SPECIFICATION SECTION 08520 – ALUMINUM WINDOWS: **ADD** paragraph 1.4.H as follows:

“H. LEED Submittals

1. Product Data for Credit MR4: For products having recycled content, documentation indicating percentages by weight of post consumer and preconsumer recycled content. Include statement indicating cost for each product having recycled content.”

7. SPECIFICATION SECTION 09772 – STRETCHED FABRIC WALL SYSTEMS: **REVISE** as follows:

a. **REVISE** paragraph 2.3.A.4 to read:

- “4. Fabric Facing Material: W7 per Finish Plans.
- 1) High Performance Stretch-in Wall Fabric - MDC Alpha 5217(Tauber MPT2507 Silver Sky)
 - 2) In addition to the following physical fabric characteristics, the Specifier/Owner reserves the right to refuse submittals based upon color, weave and texture.
 - 3) Weave Type: Dobby
 - 4) Width: 66 inches wide
 - 5) Roll Length: 50-55 yds
 - 6) Roll Weight: 47-52 lbs
 - 7) Weight: 15oz / yd
 - 8) Content: Repreve™ 100% Recycled polyester, contains a minimum of 20% Post Consumer Recycled content
 - 9) Finish: Crypton® Green Soil & Stain Protection
 - 10) Backing: Whisper Coat Acrylic Latex
 - 11) Abrasion Testing: Exceeds 100,000 double rubs/ASTM D-4157-03
 - 12) Flammability: ASTM E84, Class A

- 13) Light Fastness: A AATCC-16A Class 5.0/100 hours
- 14) Environmental: conforms to International Oeko-Tex standard 100 1 Certification. Product does not contain heavy metals, carcinogenic dyes, formaldehyde, pesticides or any other substances harmful to health and the environment.
- 15) Warranty: Limited against manufacturer's material and workmanship defects.
- 16) Maintenance: Mild water based cleaner and damp cloth."

b. **REVISE** paragraph 3.3.A.3 to read:

- "3. Tightly fit framing to adjacent construction and securely attach to existing wall finish."

c. **REVISE** paragraph 3.3.A.5 to read:

- "5. Attach frame and core to existing wall finish with adhesive or fasteners or both to support system and prevent deformation of components."

d. **REVISE** paragraph 3.3.A.6 to read:

- "6. Install stretched-fabric systems horizontal and plumb, unless otherwise indicated; true in plane; and with fabric square to the grain with straight, parallel seams."

8. **SPECIFICATION SECTION 15763 – FAN COIL UNITS:**

REVISE paragraph 1.3.B.2 to read:

- "2. Product Data for Prerequisite IEQ1: Documentation indicating that units comply with ASHRAE 62.1-2004, Section 5 – "Systems and Equipment.""

9. **SPECIFICATION SECTION 15815 – METAL DUCTS:**

REVISE as follows:

a. **REVISE** paragraph 1.4.B.1 to read:

- "1. Product Data for Prerequisite IEQ1: Documentation indicating that duct systems comply with ASHRAE 62.1, Section 5 – "Systems and Equipment.""

b. **REVISE** paragraph 1.4.B.3 to read:

- "3. Product Data for IEQ4.1: For adhesives and sealants, documentation including printed statement of VOC content."

c. **REVISE** paragraph 1.4.B.4 to read:

- “4. Laboratory Test Reports for Credit IEQ4.1: For adhesives and sealants, documentation indicating that products comply with the testing and product requirements of the California Department of Health Services Standard Practice for the Testing of Volatile Organic Emissions From Various Sources Using Small-Scale Environmental Chambers.”

II. DRAWINGS:

Item No.

1. SHEET T200 2nd Floor Code Plan – Existing Conditions:
 - a. **REVISE** Room 2227 to read “Double Room.”
 - b. **REVISE** Room 2427 to read “Storage.”
2. CIVIL SHEET C300 Detail 1: REVISE per attached drawing AD2.01.
3. ARCHITECTURAL SHEET A102 Overall Key Plan/ Floor Plan – 2nd Floor:
 - a. **REVISE** Room 2227 to read “Double Room.”
 - b. **REVISE** Room 2427 to read “Storage.”
4. ARCHITECTURAL SHEET D200:
 - a. Keynotes: **ADD** Keynote 29 as follows:

“D29 Remove (E) tackable wall system, fiberboard and fabric, see 32/D400 sim.”
 - b. General Notes:
 1. **REVISE** General Note 9 to read:

“9. Scope of work includes installation of 50 bedrooms each with 2 full sidewalls per drawings with new stretched–fabric wall system per Specification 09772, including new frame, core material and fabric to be installed with new fasteners per manufacturers recommendations over existing fabric wrapped gypsum board; and remove and replace the existing wall fabric in 50 bedrooms each with 2 full sidewalls per drawings and Specification 09772 by

removing existing fabric and installing new fabric only, with existing compatible track and core material to remain.”

2. **ADD** General Note 13 as follows:

“13. After removing curtain tracks and before painting, patch/repair all holes in walls and ceilings.”

- a. Floor Plan- Lounge 1327 & Lounge 1427: **REVISE** per attached drawing AD2.02.

5. ARCHITECTURAL SHEET D201:

- a. Keynotes: **REVISE** Keynote D3 to read:

“D3 (E) Blinds at R.D. Suite windows to be removed.”

- b. General Notes:

1. **REVISE** General Note 9 to read:

“9. Scope of work includes installation of 50 bedrooms each with 2 full sidewalls per drawings with new stretched–fabric wall system per Specification 09772, including new frame, core material and fabric to be installed with new fasteners per manufacturers recommendations over existing fabric wrapped gypsum board; and remove and replace the existing wall fabric in 50 bedrooms each with 2 full sidewalls per drawings and Specification 09772 by removing existing fabric and installing new fabric only, with existing compatible track and core material to remain.”

2. **ADD** General Note 13 as follows:

“13. After removing curtain tracks and before painting, patch/repair all holes in walls and ceilings.”

6. ARCHITECTURAL SHEET D202:

- a. Keynotes: **ADD** Keynote 29 as follows:

“D29 Remove (E) tackable wall system, fiberboard and fabric, see 32/D400 sim.”

- b. General Notes:

1. **REVISE** General Note 9 to read:

“9. Scope of work includes installation of 50 bedrooms each with 2 full sidewalls per drawings with new stretched–fabric wall system per Specification 09772, including new frame, core material and fabric to be installed with new fasteners per manufacturers recommendations over existing fabric wrapped gypsum board; and remove and replace the existing wall fabric in 50 bedrooms each with 2 full sidewalls per drawings and Specification 09772 by removing existing fabric and installing new fabric only, with existing compatible track and core material to remain.”

2. **ADD** General Note 13 as follows:

“13. After removing curtain tracks and before painting, patch/repair all holes in walls and ceilings.”

c. Floor Plan- Lounge 1127 & Lounge 1227: **REVISE** per attached drawing AD2.03.

7. ARCHITECTURAL SHEET D203:

a. Keynotes: **ADD** Keynote 28 as follows:

“D28 Remove (E) tackable wall system, fiberboard and fabric, see 32/D400 sim.”

b. General Notes:

1. **REVISE** General Note 9 to read:

“9. Scope of work includes installation of 50 bedrooms each with 2 full sidewalls per drawings with new stretched–fabric wall system per Specification 09772, including new frame, core material and fabric to be installed with new fasteners per manufacturers recommendations over existing fabric wrapped gypsum board; and remove and replace the existing wall fabric in 50 bedrooms each with 2 full sidewalls per drawings and Specification 09772 by removing existing fabric and installing new fabric only, with existing compatible track and core material to remain.”

2. **ADD** General Note 13 as follows:

“13. After removing curtain tracks and before painting, patch/repair all holes in walls and ceilings.”

c. Floor Plan- Lounge 2327 & Lounge 2408: **REVISE** per attached

drawing AD2.04.

8. ARCHITECTURAL SHEET D204:

a. Keynotes: **ADD** Keynote 28 as follows:

“D28 Remove (E) tackable wall system, fiberboard and fabric, see 32/D400 sim.”

b. General Notes:

1. **REVISE** General Note 9 to read:

“9. Scope of work includes installation of 50 bedrooms each with 2 full sidewalls per drawings with new stretched-fabric wall system per Specification 09772, including new frame, core material and fabric to be installed with new fasteners per manufacturers recommendations over existing fabric wrapped gypsum board; and remove and replace the existing wall fabric in 50 bedrooms each with 2 full sidewalls per drawings and Specification 09772 by removing existing fabric and installing new fabric only, with existing compatible track and core material to remain.”

2. **ADD** General Note 13 as follows:

“13. After removing curtain tracks and before painting, patch/repair all holes in walls and ceilings.”

c. Floor Plan- Lounge 2127 & Lounge 2208: **REVISE** per attached drawing AD2.05.

9. ARCHITECTURAL SHEETS D208 & D209 Keynotes:

REVISE Keynote D2 to read:

“D2 (E) Gyp. board ceiling to remain, prep for paint, remove (E) lighting in corridor throughout, see electrical drawings and detail 32/A600, typ. for removal and repair of fire rated light boxes.”

10. ARCHITECTURAL SHEET D400 Demolition Notes:

REVISE Demolition Note 2 to read:

“2. Scope of work includes installation of 50 bedrooms each with 2 full sidewalls per drawings with new stretched-fabric wall system per Specification 09772, including new frame, core material and fabric to be installed with new fasteners per manufacturers recommendations over existing fabric wrapped gypsum board; and

remove and replace the existing wall fabric in 50 bedrooms each with 2 full sidewalls per drawings and Specification 09772 by removing existing fabric and installing new fabric only, with existing compatible track and core material to remain.”

11. ARCHITECTURAL SHEET A200:

a. Keynotes:

1. **ADD** Keynote 23 as follows:

“23 Window coverings and tracks, furnished and installed by others”

2. **ADD** Keynote 24 as follows:

“24 Install new tackable wall system per specification 09772, including new frame, core material and fabric after removal of (E) tackable wall panels, see 23/A400 for similar installation”

b. Floor Plan – Lounge 1327 and Lounge 1427: **REVISE** per attached drawing AD2.06.

c. General Notes: **REVISE** General Note 5 to read:

“5. Scope of work includes installation of 50 bedrooms each with 2 full sidewalls per drawings with new stretched–fabric wall system per Specification 09772, including new frame, core material and fabric to be installed with new fasteners per manufacturers recommendations over existing fabric wrapped gypsum board; and remove and replace the existing wall fabric in 50 bedrooms each with 2 full sidewalls per drawings and Specification 09772 by removing existing fabric and installing new fabric only, with existing compatible track and core material to remain.”

12. ARCHITECTURAL SHEET A201:

a. Keynotes: **ADD** Keynote 31 as follows:

“31 Window coverings and tracks, furnished and installed by others”

b. Floor Plan – Recreation Room 1009 and Formal Lounge 1020:
ADD Keynote “31”

c. General Notes: **REVISE** General Note 5 to read:

- “5. Scope of work includes installation of 50 bedrooms each with 2 full sidewalls per drawings with new stretched–fabric wall system per Specification 09772, including new frame, core material and fabric to be installed with new fasteners per manufacturers recommendations over existing fabric wrapped gypsum board; and remove and replace the existing wall fabric in 50 bedrooms each with 2 full sidewalls per drawings and Specification 09772 by removing existing fabric and installing new fabric only, with existing compatible track and core material to remain.”

13. ARCHITECTURAL SHEET A202:

a. Keynotes:

1. **ADD** Keynote 23 as follows:

“23 Window coverings and tracks, furnished and installed by others”

2. **ADD** Keynote 24 as follows:

“24 Install new tackable wall system per specification 09772, including new frame, core material and fabric after removal of (E) tackable wall panels, see 23/A400 for similar installation”

b. Floor Plan:

1. Lounge 1127 and Lounge 1227: **REVISE** per attached drawing AD2.07.
2. Double Room 1241: **ADD** Window type “A” symbol to exterior window.

c. General Notes: **REVISE** General Note 5 to read:

“5. Scope of work includes installation of 50 bedrooms each with 2 full sidewalls per drawings with new stretched–fabric wall system per Specification 09772, including new frame, core material and fabric to be installed with new fasteners per manufacturers recommendations over existing fabric wrapped gypsum board; and remove and replace the existing wall fabric in 50 bedrooms each with 2 full sidewalls per drawings and Specification 09772 by removing existing fabric and installing new fabric only, with existing compatible track and core material to remain.”

14. ARCHITECTURAL SHEET A203:

a. Keynotes:

1. **ADD** Keynote 23 as follows:

“23 Provide new aluminum window with two (2) security screens in lieu of glass fiber mesh window screens, see A500 Window Schedule and details 41, 42, & 43/A602”

2. **ADD** Keynote 24 as follows:

“24 Window coverings and tracks furnished and installed by others”

3. **ADD** Keynote 25 as follows:

“25 Install new tackable wall system per specification 09772, including new frame, core material and fabric after removal of (E) tackable wall panels, see 23/A400 for similar installation”

b. Floor Plan – Lounge 2408

1. **REVISE** Keynote “5” to be Keynote “23”

2. **REMOVE** Keynote “2” and “20”

3. **REVISE** per attached drawing AD2.08.

c. Floor Plan-Lounge 2327

1. **REVISE** per attached drawing AD2.08.

d. General Notes: **REVISE** General Note 5 to read:

“5. Scope of work includes installation of 50 bedrooms each with 2 full sidewalls per drawings with new stretched-fabric wall system per Specification 09772, including new frame, core material and fabric to be installed with new fasteners per manufacturers recommendations over existing fabric wrapped gypsum board; and remove and replace the existing wall fabric in 50 bedrooms each with 2 full sidewalls per drawings and Specification 09772 by removing existing fabric and installing new fabric only, with existing compatible track and core material to remain.”

15. ARCHITECTURAL SHEET A204:

a. Keynotes:

1. **ADD** Keynote 23 as follows:

“23 Provide new aluminum window with two (2) security screens in lieu of glass fiber mesh window screens, see A500 Window Schedule and details 41, 42, & 43/A602”

2. **ADD** Keynote 24 as follows:

“24 Window coverings and tracks furnished and installed by others”

3. **ADD** Keynote 25 as follows:

“25 Install new tackable wall system per specification 09772, including new frame, core material and fabric after removal of (E) tackable wall panels, see 23/A400 for similar installation”

b. Floor Plan – Lounge 2208

1. **REVISE** Keynote “5” to be Keynote “23”

2. **REMOVE** Keynote “20”

3. **REVISE** per attached drawing AD2.09.

c. Floor Plan-Lounge 2127

1. **REVISE** per attached drawing AD2.09.

d. General Notes: **REVISE** General Note 5 to read:

“5. Scope of work includes installation of 50 bedrooms each with 2 full sidewalls per drawings with new stretched-fabric wall system per Specification 09772, including new frame, core material and fabric to be installed with new fasteners per manufacturers recommendations over existing fabric wrapped gypsum board; and remove and replace the existing wall fabric in 50 bedrooms each with 2 full sidewalls per drawings and Specification 09772 by removing existing fabric and installing new fabric only, with existing compatible track and core material to remain.”

16. ARCHITECTURAL SHEETS A208 & A209 Keynotes:

REVISE Keynote 4 to read:

“4 New lighting, see electrical drawings and provide 1 hour ceiling at new light locations per detail 14/A600.”

17. ARCHITECTURAL SHEET A211 Finish Plan – 1st Floor Area B:
REVISE Flooring finish in Reception Lobby alcoves per attached drawing AD2.10.

18. ARCHITECTURAL SHEETS A210, A211, A212, A213 & A214:
 - a. Material Schedule: **REVISE** Surface A1 to read:

“Avonite Foundations Cozumel K3-8575”

 - b. Finish Schedule Remarks: **REVISE** Note 1 to read:

“Scope of work includes installation of 50 bedrooms each with 2 full sidewalls per drawings with new stretched–fabric wall system per Specification 09772, including new frame, core material and fabric to be installed with new fasteners per manufacturers recommendations over existing fabric wrapped gypsum board; and remove and replace the existing wall fabric in 50 bedrooms each with 2 full sidewalls per drawings and Specification 09772 by removing existing fabric and installing new fabric only, with existing compatible track and core material to remain.”

 - c. General Notes: **DELETE** Note 5 in its entirety:

19. ARCHITECTURAL SHEET A301 Building Section 11:
REVISE partially missing interior elevation callout to read:

“34/A400 Sim.”

20. ARCHITECTURAL SHEET A302:
REVISE Wall Section 25 per attached drawing AD2.11.

21. ARCHITECTURAL SHEET A400:
 - a. Keynotes: **REVISE** Keynote 3 to read:

“3 (E) Fabric covered panels to remain, be repaired, or replaced, for extent of work see General Notes 2 and 6”

 - b. General Notes: **REVISE** General Note 2 to read:

“2. Scope of work includes installation of 50 bedrooms each with 2 full sidewalls per drawings with new stretched–fabric wall system per Specification 09772, including new frame, core material and fabric to be installed with new fasteners per manufacturers recommendations over existing fabric wrapped gypsum board; and remove and replace the existing wall fabric in 50 bedrooms each

with 2 full sidewalls per drawings and Specification 09772 by removing existing fabric and installing new fabric only, with existing compatible track and core material to remain.”

c. General Notes: **ADD** General Note 6 as follows:

“6. The layout for the 50 rooms with entire new tackable wall systems will consist of 2 horizontal panels. The upper panel will be 65” full width of the fabric and the lower panel will cover the remaining portion of the wall.”

22. ARCHITECTURAL SHEET A401 Keynotes:

- a. **REVISE** Keynote 12 to read:
“12 (E) Metal Door and frame- do not paint”
- b. **REVISE** Keynote 14 to read:
“14 (E) Window and frame- do not paint”

23. ARCHITECTURAL SHEET A402 Keynotes:

- a. **REVISE** Keynote 3 to read:
“3 New Microwave – Basis of Design, General Electric Spacemaker 11, 1.0 cu. Ft. model #JEM25DNWW2 or equal.”
- b. **REVISE** Keynote 14 to read:
“14 New Refrigerator – Basis of Design, Danby model #DFF261WDB”

24. ARCHITECTURAL SHEET A501 Detail 44:

REVISE detail title to read:

“Frame Anchor”

25. ARCHITECTURAL SHEET A601 Detail 42:

REVISE detail title to read:

“4 HR Rated Wall Penetration”

26. ARCHITECTURAL SHEET A602:

ADD signage mounting detail 53 per attached drawing AD2.12.

27. ELECTRICAL SHEET E100:

REVISE Typical Communications Riser detail D per attached drawing AD2.13.

III. CLARIFICATIONS:

Item No.

1. **QUESTION:** In regards to the demo of existing flooring, drawings call for existing flooring and adhesive to be removed. It is impossible to determine the extent and types of adhesives used throughout the buildings and such it is impossible to quantify and cost as the adhesives are covered with flooring. The costs in time and money to remove the adhesives may be an unneeded expense as the specified carpet is a glue less system. Having said that does the adhesive still need to be removed.

RESPONSE: Refer to the Interface Installation Guide that discusses removal and installation of flooring on the internet at:

https://www.interfaceflor.com/PDF/Products/Technical/Installation_GlasBac_RE_Ta cTiles_32012.pdf

2. **QUESTION:**

- a. Refer to Architectural Plans sheet D200, Keynote D5: This keynote refers to general note #9 " Removal and replacement of 50 bedrooms with entire new tackable wall systems, fiberboard and fabric, and 50 bedrooms with new wall fabric, existing tackable wall systems and fiberboard to remain.
- b. Will there be any additional work for the remaining bedroom tackable walls? If repair work is to be done, we would have to see each and every one of those bedrooms.

RESPONSE:

- a. Refer to Unit Prices, Section 01026, Section 2, Subparagraph 2.01, Unit Price No. 1 for any additional work to the remaining bedroom tackable walls.
- b. Housing & Residential Services will determine which panels and fabrics are to be replaced, both for the base bid; and the unit price work, if they choose to do the additional work.

IV. GENERAL:

Item No.

1. This project requires the payment of the California Department of Industrial Relations general commercial prevailing wage rates.

END OF ADDENDUM NO. 2



RA
 RAVATT, ALBRECHT
 & ASSOCIATES
 3203 LIGHTNING STREET
 PO BOX 528
 SANTA MARIA CA 93456
 (805) 928-5002

These drawings are instruments of service and are the property of RA & Associates. The design and information represented on these drawings are exclusively for the project indicated and shall not be transferred or otherwise reproduced without express written permission of RA & Associates. Copyright 2013. Written dimensions take precedence over scaled dimensions. Do not scale plans. Contractor shall verify all dimensions and conditions in the field. Any discrepancies shall be called to the attention of RA & Associates.

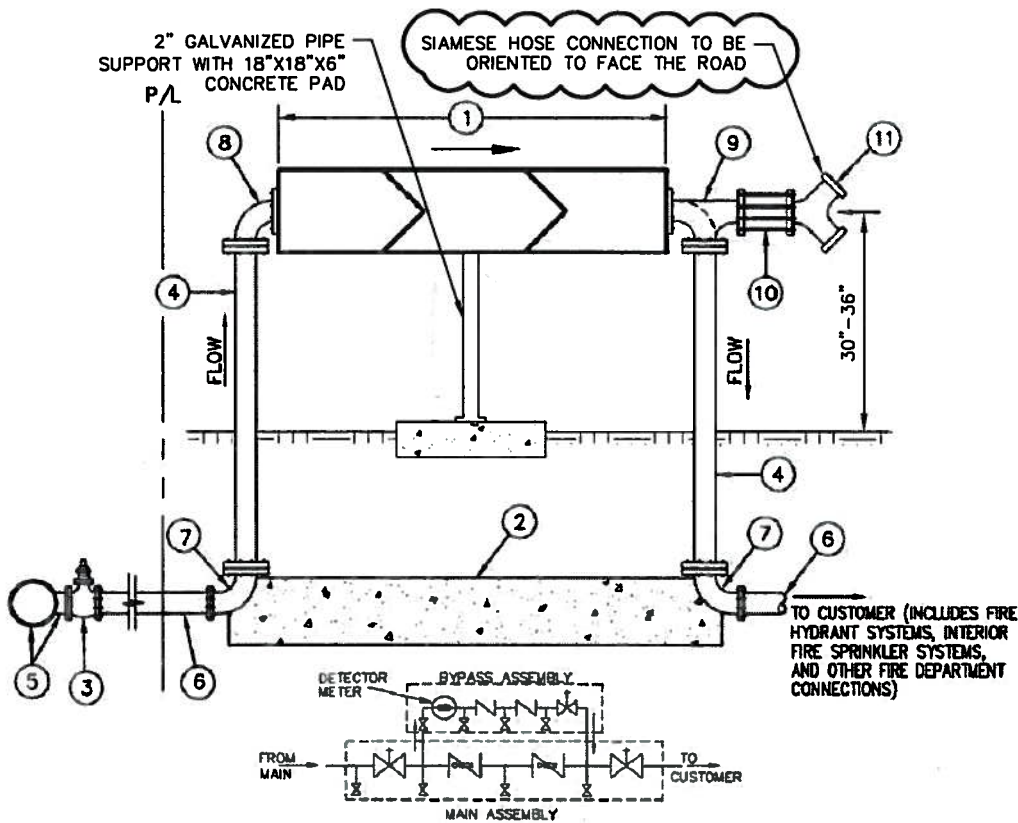

ITEM	QTY.	DESCRIPTION
1	1	APPROVED DOUBLE CHECK DETECTOR ASSEMBLY (D.C.D.A.)
2	1	THRUST BLOC, H = W = 3D ± 3D, D = PIPE DIAMETER
3	1	GATE VALVE, FL X MJ, WITH RETAINER GLAND, 8" MIN.
4	2	DRP OR STEEL FLANGED SPOOL
5	1	TEE - MJ X FL FOR NEW PVC MAIN, TAPPING SLEEVE FOR EXIST. MAIN, 6" MIN.
6	VAR	CL 200 PVC PIPE, ANAMA CG90, WITH JOINT HARNESSES
7	2	90 DEGREE BEND, MJ X FL, WITH RETAINER GLAND
8	2	90 DEGREE BEND, FL X FL
9	1	90 DEGREE BEND, FL X FL (OR TEE, FL X FL WHERE FIRE CONNECTION REQUIRED)
10	1	(NAUFER STYLE, SILENT CHECK VALVE, OR APPROVED EQUAL WHERE FIRE CONNECTION REQUIRED)
11	1	SIAMESE HOSE CONNECTION WITH NPT THREADS AS REQUIRED BY SANTA BARBARA COUNTY FIRE DEPARTMENT

NOTES

- SEE PROJECT SPECIFICATIONS FOR APPROVED MATERIALS AND MANUFACTURERS.
- THE DCDA SHALL BE TESTED AND APPROVED BY A CERTIFIED TESTER PRIOR TO ACCEPTANCE.
- ALL TEST COCKS SHALL BE 1/4" DIAMETER.
- ALL BURIED FERROUS PIPE AND FITTINGS SHALL BE TAPE WRAPPED.
- ALL EXPOSED METAL PIPE SHALL BE PAINTED PER THE PROJECT SPECIFICATIONS.
- HANDLES OF METER ISOLATION BALL VALVES SHALL BE REMOVED AND DELIVERED TO THE UNIVERSITY INSPECTOR.

DCDA AND FDC CONNECTION

N.T.S.



C300 - CIVIL DETAILS

University of California Santa Barbara
 Anacapa Fire Safety and Renewal Building #547
 Santa Barbara CA 93106
 FM 130245L / 988650

UCSB DWG #
 547-114
 DATE
 04/10/13

AD
 2.01

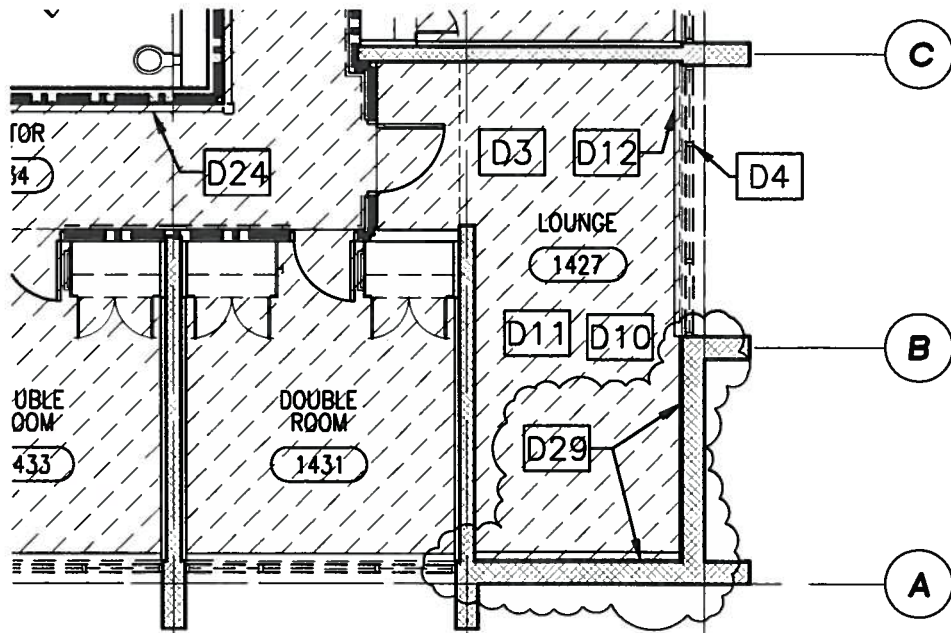

DEMO PLAN - ROOM 1427

SCALE: 1/8" = 1'-0"

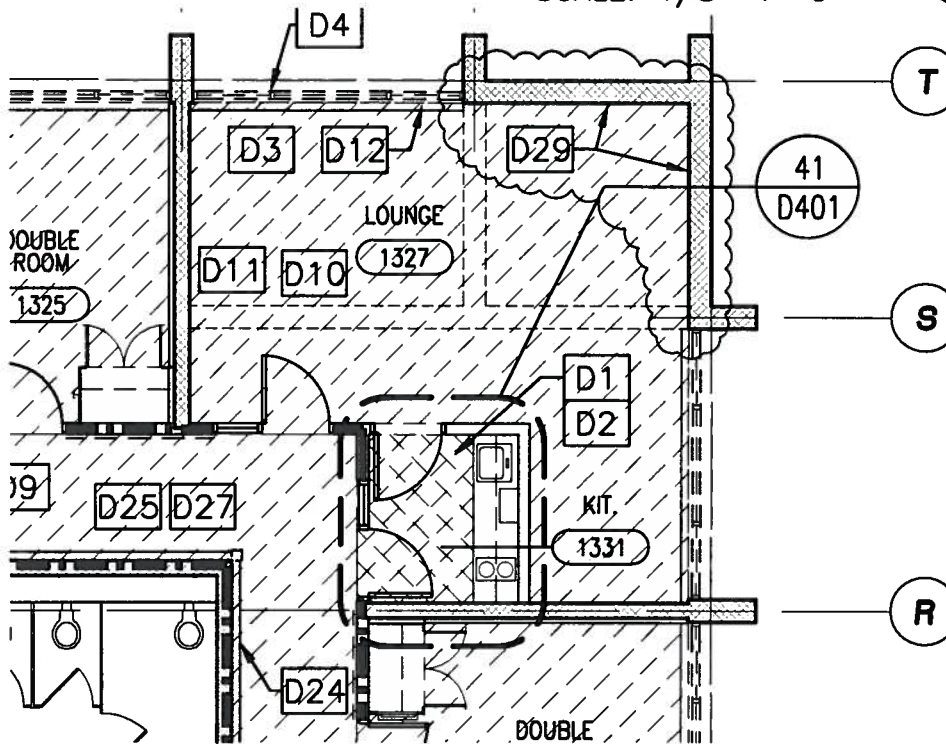

DEMO PLAN - ROOM 1327

SCALE: 1/8" = 1'-0"

D29 REMOVE (E) TACKABLE WALL SYSTEM, FIBERBOARD AND FABRIC, SEE 32/D400 SIM.

KEYNOTES



RA
 RAVATT, ALBRECHT
 & ASSOCIATES
 3203 LIGHTNING STREET
 PO BOX 528
 SANTA MARIA CA 93456
 (805) 928-5002

These drawings are instruments of service and are the property of RA & Associates. The design and information represented on these drawings are exclusively for the project indicated and shall not be transferred or otherwise reproduced without express written permission of RA & Associates. Copyright 2013. Written dimensions take precedence over scaled dimensions. Do not scale plans. Contractor shall verify all dimensions and conditions in the field. Any discrepancies shall be called to the attention of RA & Associates.

TACKABLE WALL SYSTEMS AT LOUNGES

University of California Santa Barbara

Anacapa Fire Safety and Renewal Building #547

Santa Barbara CA 93106

FM 130245L / 988650

UCSB DWG #	AD
547-114	
DATE	2.02
04/10/13	

34
D200

41
D401

34
D200

14
D200

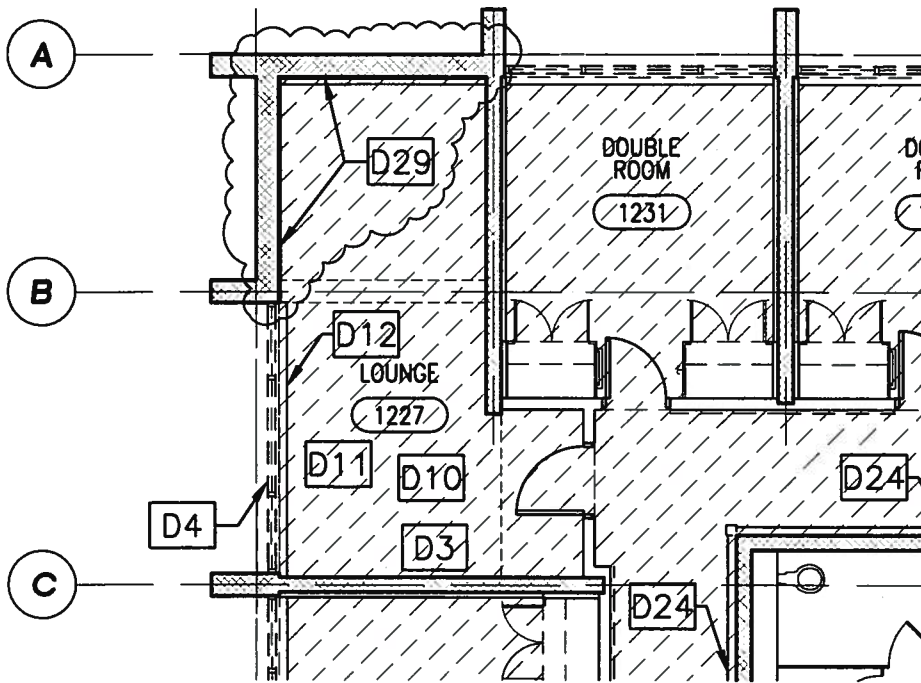

DEMO PLAN - ROOM 1227

SCALE: 1/8"=1'-0"

34
D202

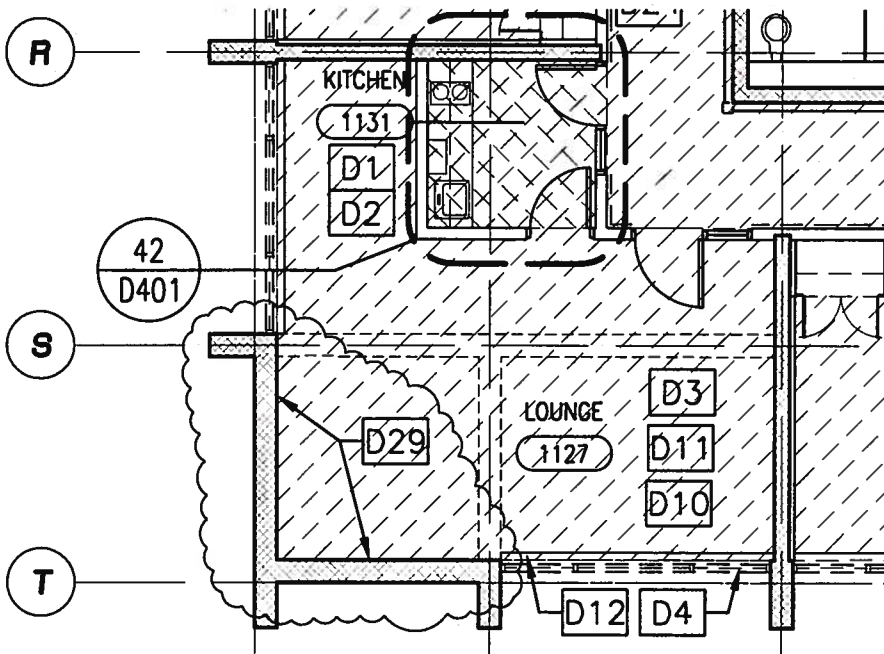

DEMO PLAN - ROOM 1127

SCALE: 1/8"=1'-0"

34
D202

D29 REMOVE (E) TACKABLE WALL SYSTEM, FIBERBOARD AND FABRIC, SEE 32/D400 SIM.

KEYNOTES

14
D202



RA
RAVATT, ALBRECHT
& ASSOCIATES
3203 LIGHTNING STREET
PO BOX 528
SANTA MARIA CA 93456
(805) 928-5002

These drawings are instruments of service and are the property of RA & Associates. The design and information represented on these drawings are exclusively for the project indicated and shall not be transferred or otherwise reproduced without express written permission of RA & Associates. Copyright 2013. Written dimensions take precedence over scaled dimensions. Do not scale plans. Contractor shall verify all dimensions and conditions in the field. Any discrepancies shall be called to the attention of RA & Associates.

TACKABLE WALL SYSTEMS AT LOUNGES

University of California Santa Barbara
Anacapa Fire Safety and Renewal Building #547
Santa Barbara CA 93106
FM 130245L / 988650

UCSB DWG # 547-114	AD
DATE 04/10/13	2.03

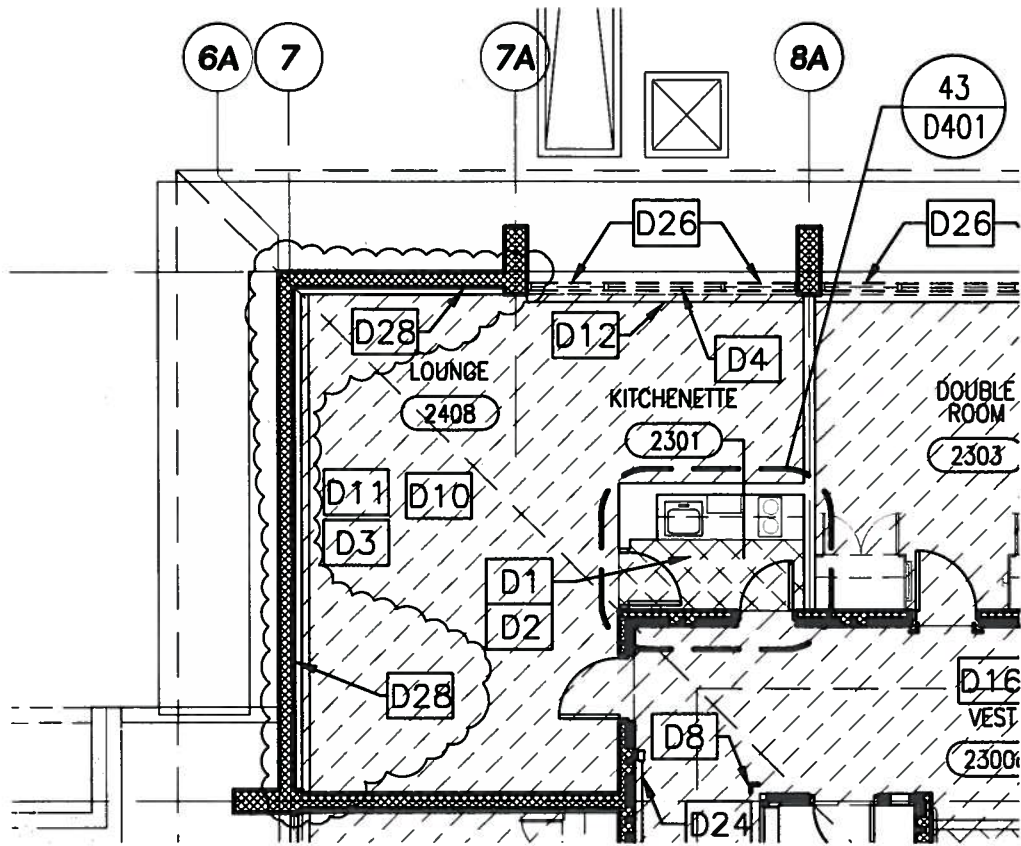

DEMO PLAN - ROOM 2408

SCALE: 1/8"=1'-0"

34
D203

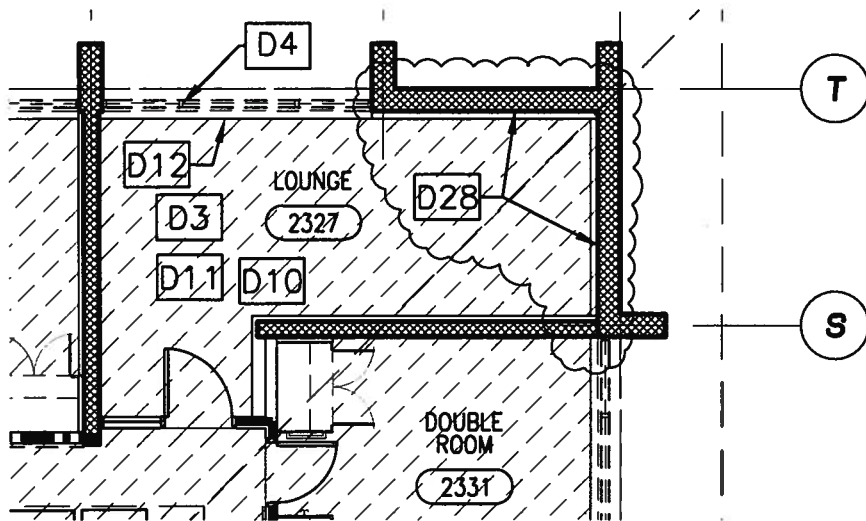

DEMO PLAN - ROOM 2327

SCALE: 1/8"=1'-0"

34
D203

D28 REMOVE (E) TACKABLE WALL SYSTEMS, FIBERBOARD AND FABRIC, SEE 32/D400 SIM.

KEYNOTES

14
D203



RA
RAVATT, ALBRECHT
& ASSOCIATES
3203 LIGHTNING STREET
PO BOX 528
SANTA MARIA CA 93456
(805) 928-5002

These drawings are instruments of service and are the property of RA & Associates. The design and information represented on these drawings are exclusively for the project indicated and shall not be transferred or otherwise reproduced without express written permission of RA & Associates. Copyright 2013. Written dimensions take precedence over scaled dimensions. Do not scale plans. Contractor shall verify all dimensions and conditions in the field. Any discrepancies shall be called to the attention of RA & Associates.

TACKABLE WALL SYSTEMS AT LOUNGES

University of California Santa Barbara
Anacapa Fire Safety and Renewal Building #547
Santa Barbara CA 93106
FM 130245L / 988650

UCSB DWG # 547-114	AD
DATE 04/10/13	2.04

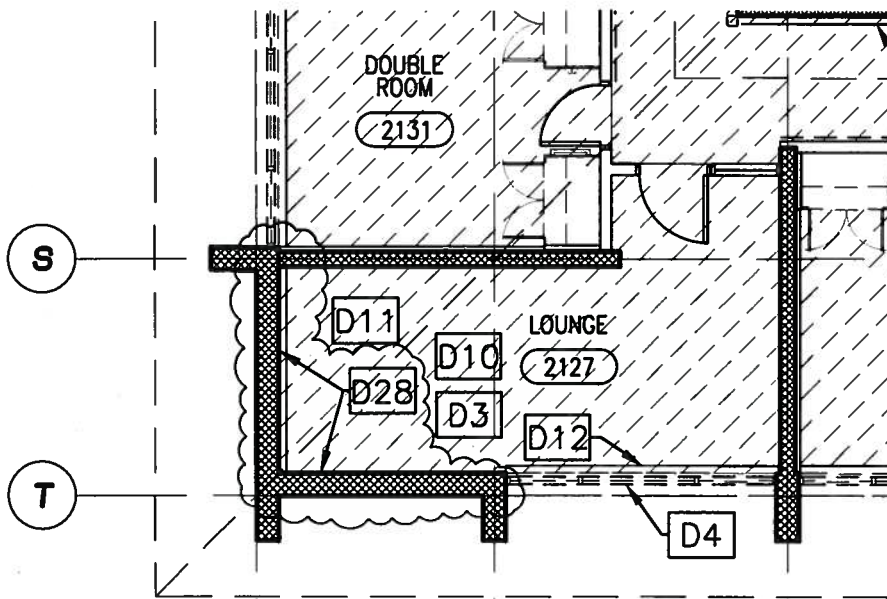

DEMO PLAN - ROOM 2127

SCALE: 1/8"=1'-0"

34
D204

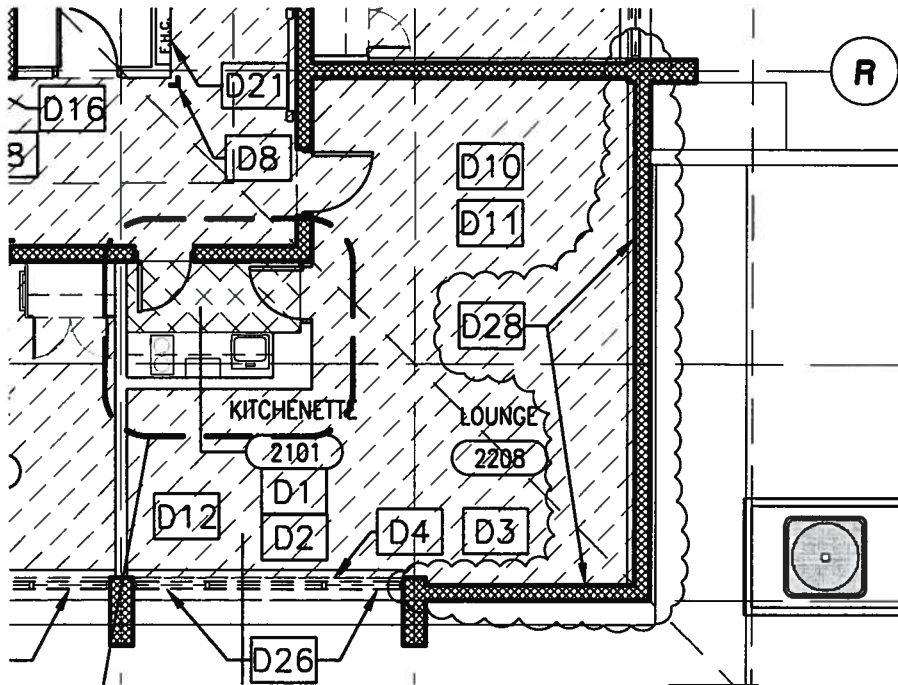

DEMO PLAN - ROOM 2208

SCALE: 1/8"=1'-0"

34
D204

D28 REMOVE (E) TACKABLE WALL SYSTEMS, FIBERBOARD AND FABRIC, SEE 32/D400 SIM.

KEYNOTES

14
D204



RA
RAVATT, ALBRECHT
& ASSOCIATES
3203 LIGHTNING STREET
PO BOX 528
SANTA MARIA CA 93456
(805) 928-5002

These drawings are instruments of service and are the property of RA & Associates. The design and information represented on these drawings are exclusively for the project indicated and shall not be transferred or otherwise reproduced without express written permission of RA & Associates. Copyright 2013. Written dimensions take precedence over scaled dimensions. Do not scale plans. Contractor shall verify all dimensions and conditions in the field. Any discrepancies shall be called to the attention of RA & Associates.

TACKABLE WALL SYSTEMS AT LOUNGES

University of California Santa Barbara
Anacapa Fire Safety and Renewal Building #547
Santa Barbara CA 93106
FM 130245L / 988650

UCSB DWG #
547-114

DATE
04/10/13

AD
2.05

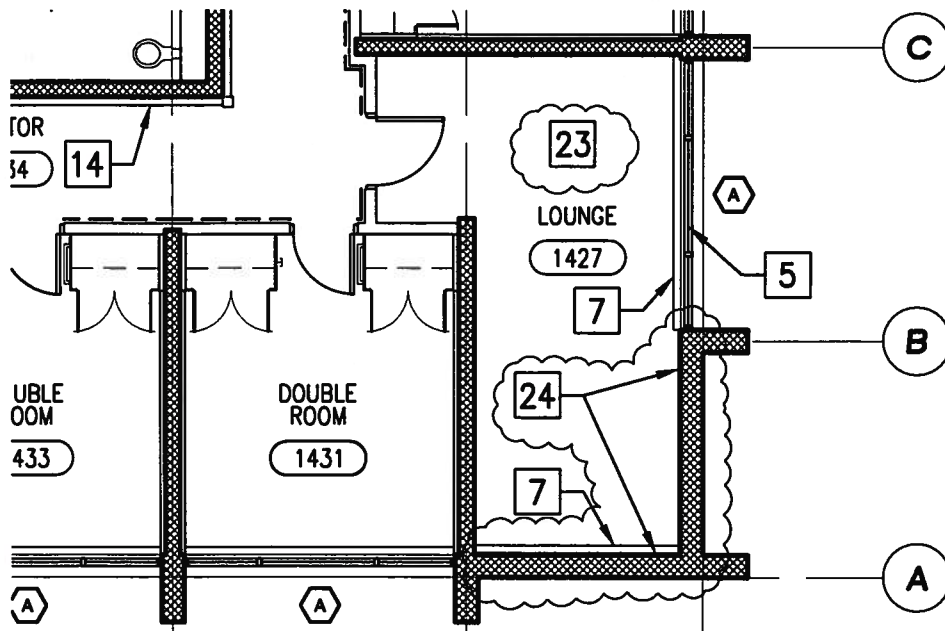

FLOOR PLAN - ROOM 1427

SCALE: 1/8" = 1'-0"

34
A200

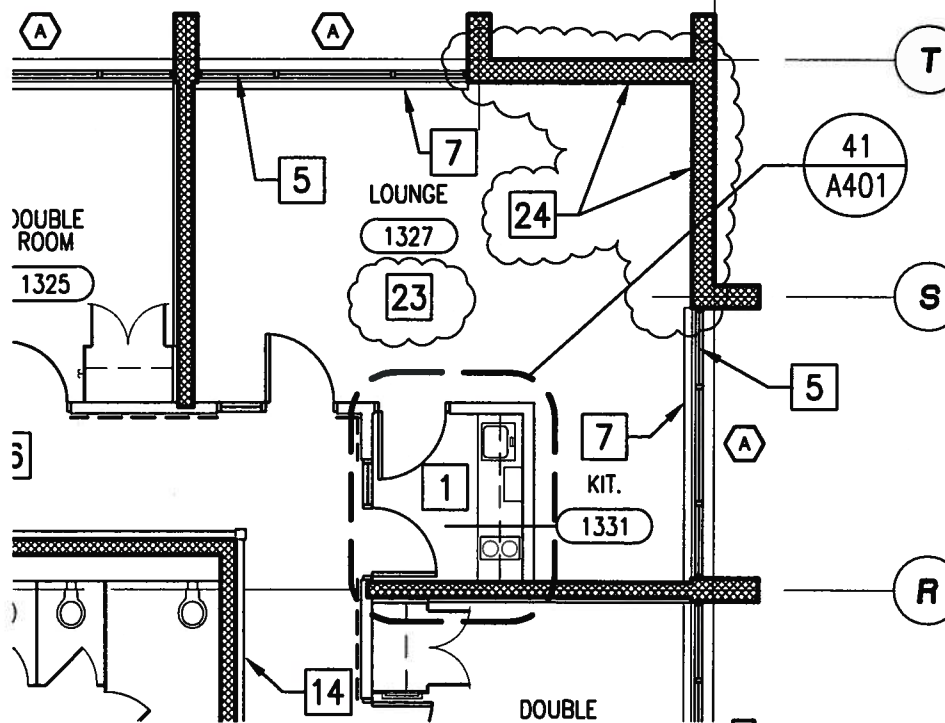

FLOOR PLAN - ROOM 1327

SCALE: 1/8" = 1'-0"

34
A200

23 WINDOW COVERINGS AND TRACKS, FURNISHED AND INSTALLED BY OTHERS

24 INSTALL NEW TACKABLE WALL SYSTEM PER SPECIFICATION 09772, INCLUDING NEW FRAME, CORE MATERIAL AND FABRIC AFTER REMOVAL OF (E) TACKABLE WALL PANELS, SEE 23/A400 FOR SIMILAR INSTALLATION

KEYNOTES

14
A200

RA
 RAVATT, ALBRECHT
 & ASSOCIATES
 3203 LIGHTNING STREET
 PO BOX 528
 SANTA MARIA CA 93456
 (805) 928-5002

These drawings are instruments of service and are the property of RA & Associates. The design and information represented on these drawings are exclusively for the project indicated and shall not be transferred or otherwise reproduced without express written permission of RA & Associates. Copyright 2013. Written dimensions take precedence over scaled dimensions. Do not scale plans. Contractor shall verify all dimensions and conditions in the field. Any discrepancies shall be called to the attention of RA & Associates.

TACKABLE WALL SYSTEMS AT LOUNGES

University of California Santa Barbara
 Anacapa Fire Safety and Renewal Building #547
 Santa Barbara CA 93106
 FM 130245L / 988650

UCSB DWG #	AD
547-114	
DATE	2.06
04/10/13	

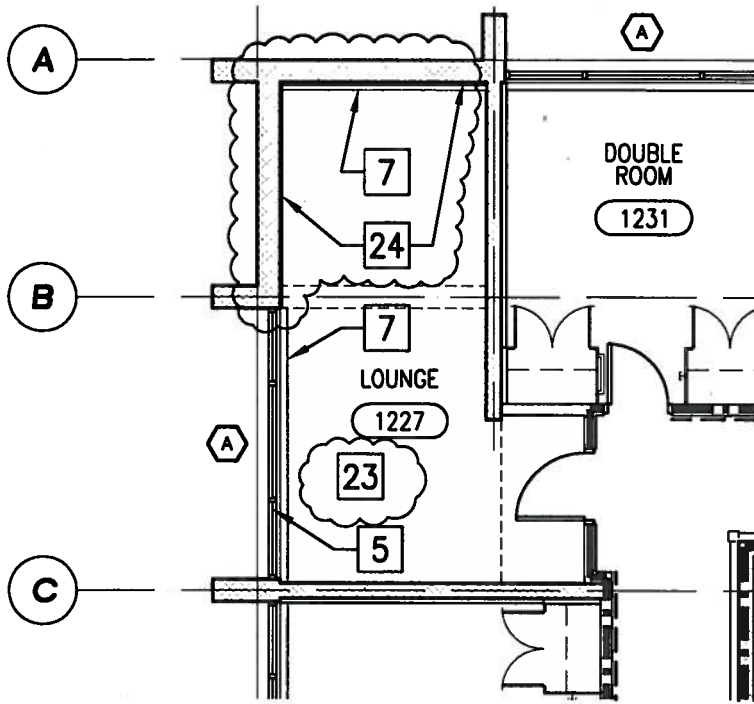

FLOOR PLAN - ROOM 1227

SCALE: 1/8"=1'-0"

34
A202

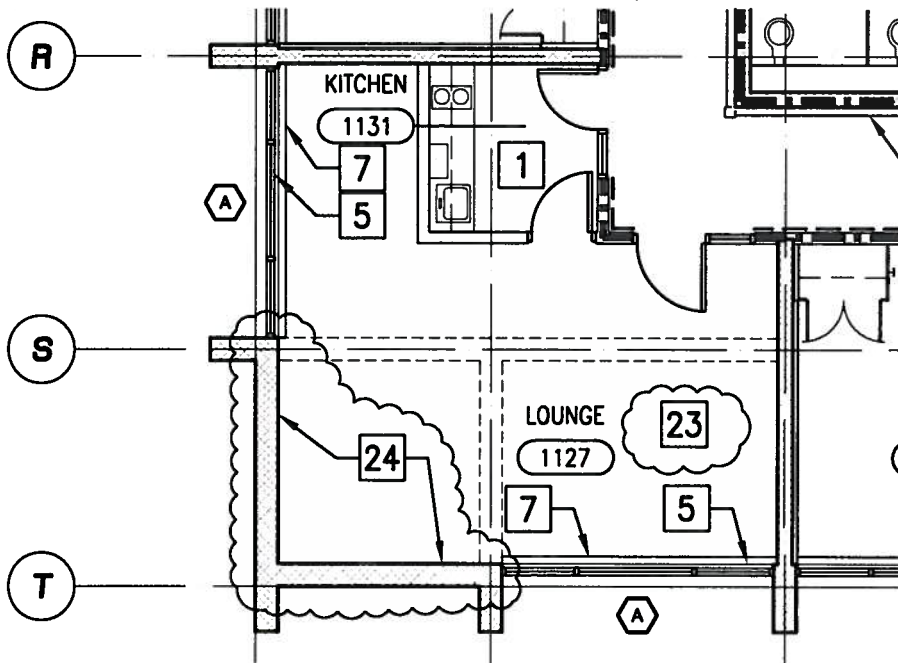

FLOOR PLAN - ROOM 1127

34
A202

23 WINDOW COVERINGS AND TRACKS, FURNISHED AND INSTALLED BY OTHERS SCALE: 1/8"=1'-0"

24 INSTALL NEW TACKABLE WALL SYSTEM PER SPECIFICATION 09772, INCLUDING NEW FRAME, CORE MATERIAL AND FABRIC AFTER REMOVAL OF (E) TACKABLE WALL PANELS, SEE 23/A400 FOR SIMILAR INSTALLATION

KEYNOTES

12
A202

RA
 RAVATT, ALBRECHT & ASSOCIATES
 3203 LIGHTNING STREET
 PO BOX 528
 SANTA MARIA CA 93456
 (805) 928-5002

These drawings are instruments of service and are the property of RA & Associates. The design and information represented on these drawings are exclusively for the project indicated and shall not be transferred or otherwise reproduced without express written permission of RA & Associates. Copyright 2013. Written dimensions take precedence over scaled dimensions. Do not scale plans. Contractor shall verify all dimensions and conditions in the field. Any discrepancies shall be called to the attention of RA & Associates.

TACKABLE WALL SYSTEMS AT LOUNGES

University of California Santa Barbara
 Anacapa Fire Safety and Renewal Building #547
 Santa Barbara CA 93106
 FM 130245L / 988650

UCSB DWG # 547-114	AD
DATE 04/10/13	2.07

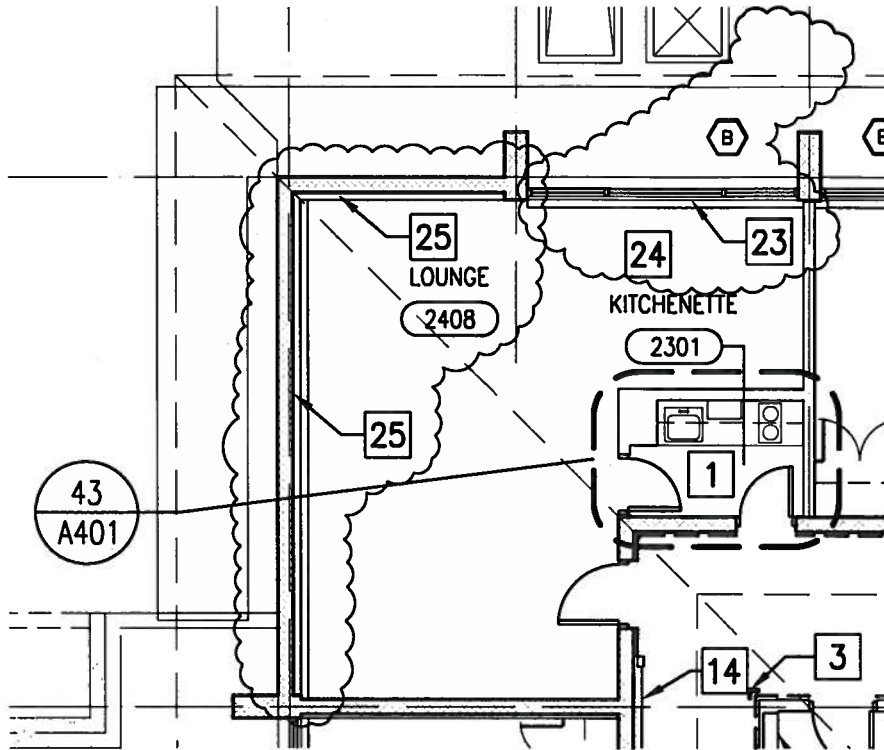

FLOOR PLAN - ROOM 2408

SCALE: 1/8"=1'-0"

34
A203

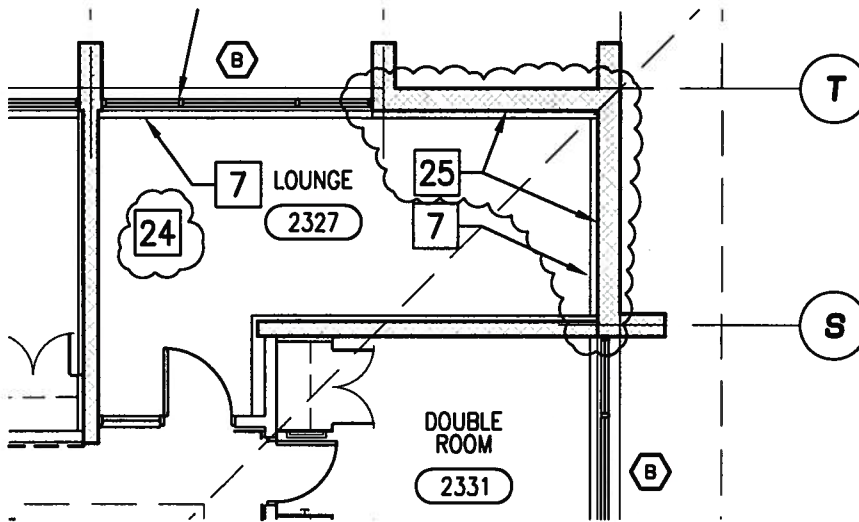

FLOOR PLAN - ROOM 2327

SCALE: 1/8"=1'-0"

34
A203

- 23** PROVIDE NEW ALUMINUM WINDOW WITH TWO (2) SECURITY SCREENS IN LIEU OF GLASS FIBER MESH WINDOW SCREENS, SEE A500 WINDOW SCHEDULE AND DETAILS 41,42, & 43/A602
- 24** WINDOW COVERINGS AND TRACKS FURNISHED AND INSTALLED BY OTHERS
- 25** INSTALL NEW TACKABLE WALL SYSTEM PER SPECIFICATION 09772, INCLUDING NEW FRAME, CORE MATERIAL AND FABRIC AFTER REMOVAL OF (E) TACKABLE WALL PANELS, SEE 23/A400 FOR SIMILAR INSTALLATION

KEYNOTES

14
A203

RA
 RAVATT, ALBRECHT
 & ASSOCIATES
 3203 LIGHTNING STREET
 PO BOX 528
 SANTA MARIA CA 93456
 (805) 928-5002

These drawings are instruments of service and are the property of RA & Associates. The design and information represented on these drawings are exclusively for the project indicated and shall not be transferred or otherwise reproduced without express written permission of RA & Associates. Copyright 2013. Written dimensions take precedence over scaled dimensions. Do not scale plans. Contractor shall verify all dimensions and conditions in the field. Any discrepancies shall be called to the attention of RA & Associates.

TACKABLE WALL SYSTEMS AT LOUNGES

University of California Santa Barbara
 Anacapa Fire Safety and Renewal Building #547
 Santa Barbara CA 93106
 FM 130245L / 988650

UCSB DWG #	AD
547-114	
DATE	2.08
04/10/13	

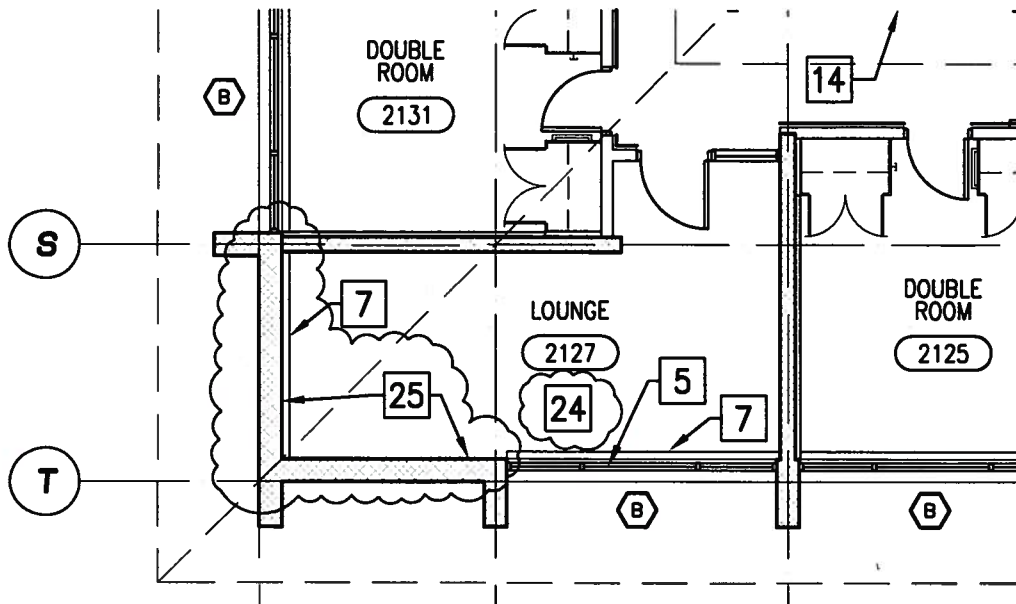

FLOOR PLAN - ROOM 2127

SCALE: 1/8" = 1'-0"

34
A204

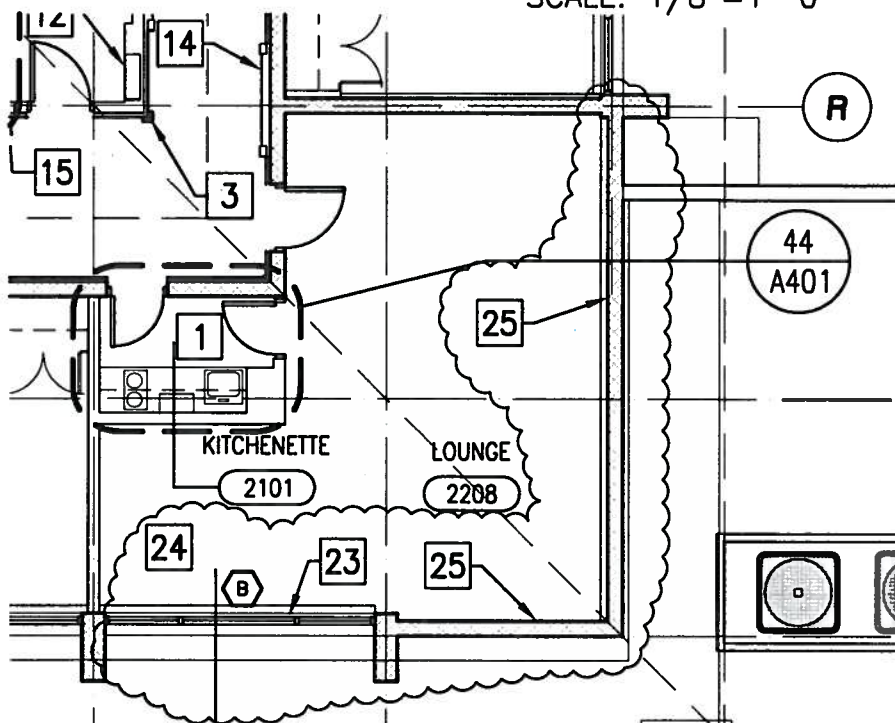

FLOOR PLAN - ROOM 2208

SCALE: 1/8" = 1'-0"

34
A204

- 23** PROVIDE NEW ALUMINUM WINDOW WITH TWO (2) SECURITY SCREENS IN LIEU OF GLASS FIBER MESH WINDOW SCREENS, SEE A500 WINDOW SCHEDULE AND DETAILS 41,42, & 43/A602
- 24** WINDOW COVERINGS AND TRACKS FURNISHED AND INSTALLED BY OTHERS
- 25** INSTALL NEW TACKABLE WALL SYSTEM PER SPECIFICATION 09772, INCLUDING NEW FRAME, CORE MATERIAL AND FABRIC AFTER REMOVAL OF (E) TACKABLE WALL PANELS, SEE 23/A400 FOR SIMILAR INSTALLATION

KEYNOTES

12
A204



RA
RAVATT, ALBRECHT
& ASSOCIATES
3203 LIGHTNING STREET
PO BOX 528
SANTA MARIA CA 93456
(805) 928-5002

These drawings are instruments of service and are the property of RA & Associates. The design and information represented on these drawings are exclusively for the project indicated and shall not be transferred or otherwise reproduced without express written permission of RA & Associates. Copyright 2013. Written dimensions take precedence over scaled dimensions. Do not scale plans. Contractor shall verify all dimensions and conditions in the field. Any discrepancies shall be called to the attention of RA & Associates.

TACKABLE WALL SYSTEMS AT LOUNGES

University of California Santa Barbara
Anacapa Fire Safety and Renewal Building #547
Santa Barbara CA 93106
FM 130245L / 988650

UCSB DWG # 547-114	AD
DATE 04/10/13	2.09

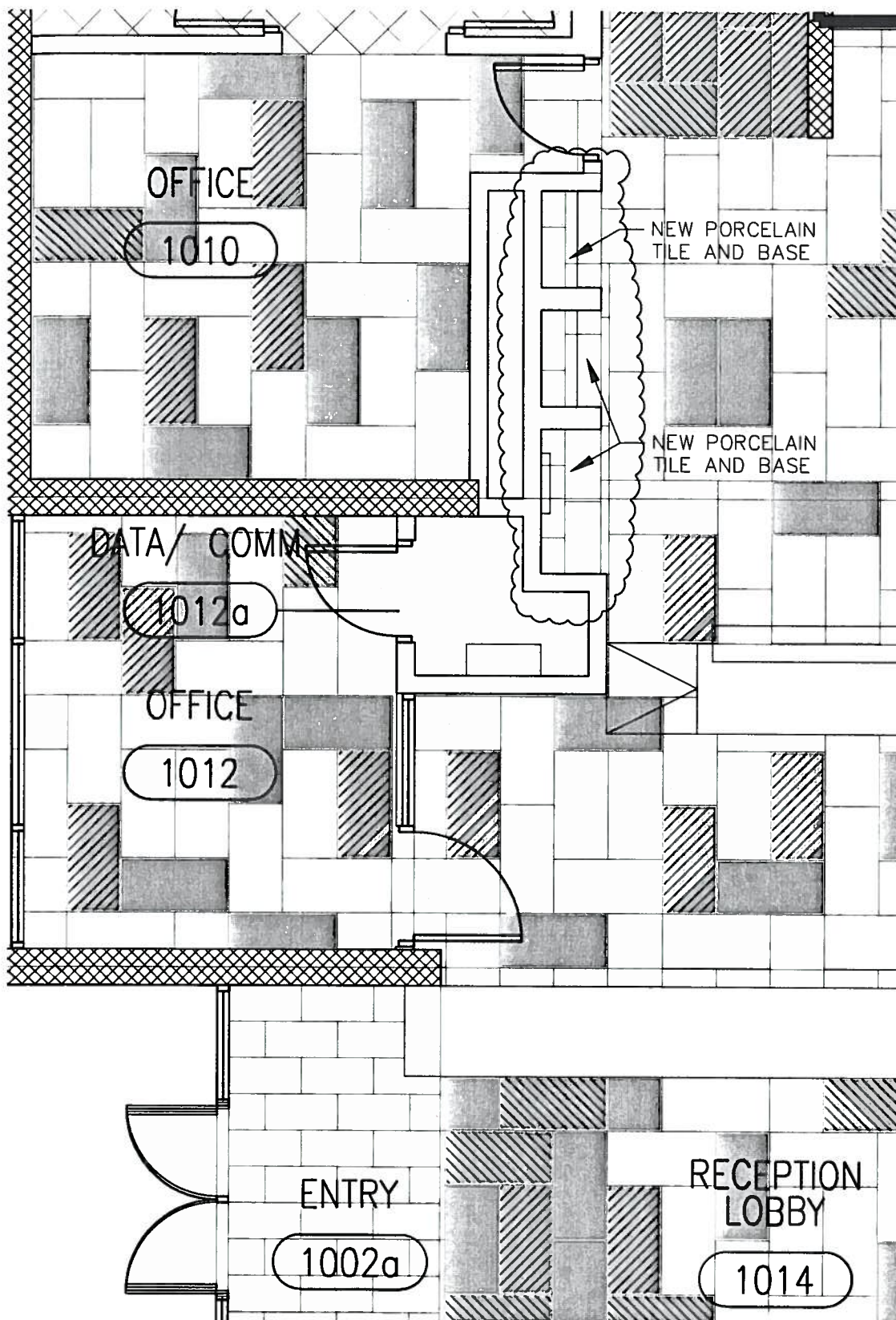

RAVATT, ALBRECHT & ASSOCIATES
 3203 LIGHTNING STREET
 PO BOX 528
 SANTA MARIA CA 93456
 (805) 928-5002

These drawings are instruments of service and are the property of RA & Associates. The design and information represented on these drawings are exclusively for the project indicated and shall not be transferred or otherwise reproduced without express written permission of RA & Associates. Copyright 2013. Written dimensions take precedence over scaled dimensions. Do not scale plans. Contractor shall verify all dimensions and conditions in the field. Any discrepancies shall be called to the attention of RA & Associates.

FINISH PLAN- 1ST FLOOR AREA B

University of California Santa Barbara
 Anacapa Fire Safety and Renewal Building #547
 Santa Barbara CA 93106
 FM 130245L / 988650

FINISH PLAN - AREA B

SCALE: 1/4"=1'-0"

34
A211

UCSB DWG #	AD
547-114	
DATE	2.10
04/10/13	



RA
 RAVATT, ALBRECHT
 & ASSOCIATES
 3203 LIGHTNING STREET
 PO BOX 528
 SANTA MARIA CA 93456
 (805) 928-5002

These drawings are instruments of service and are the property of RA & Associates. The design and information represented on these drawings are exclusively for the project indicated and shall not be transferred or otherwise reproduced without express written permission of RA & Associates. Copyright 2013
 Written dimensions take precedence over scaled dimensions. Do not scale plans. Contractor shall verify all dimensions and conditions in the field. Any discrepancies shall be called to the attention of RA & Associates.

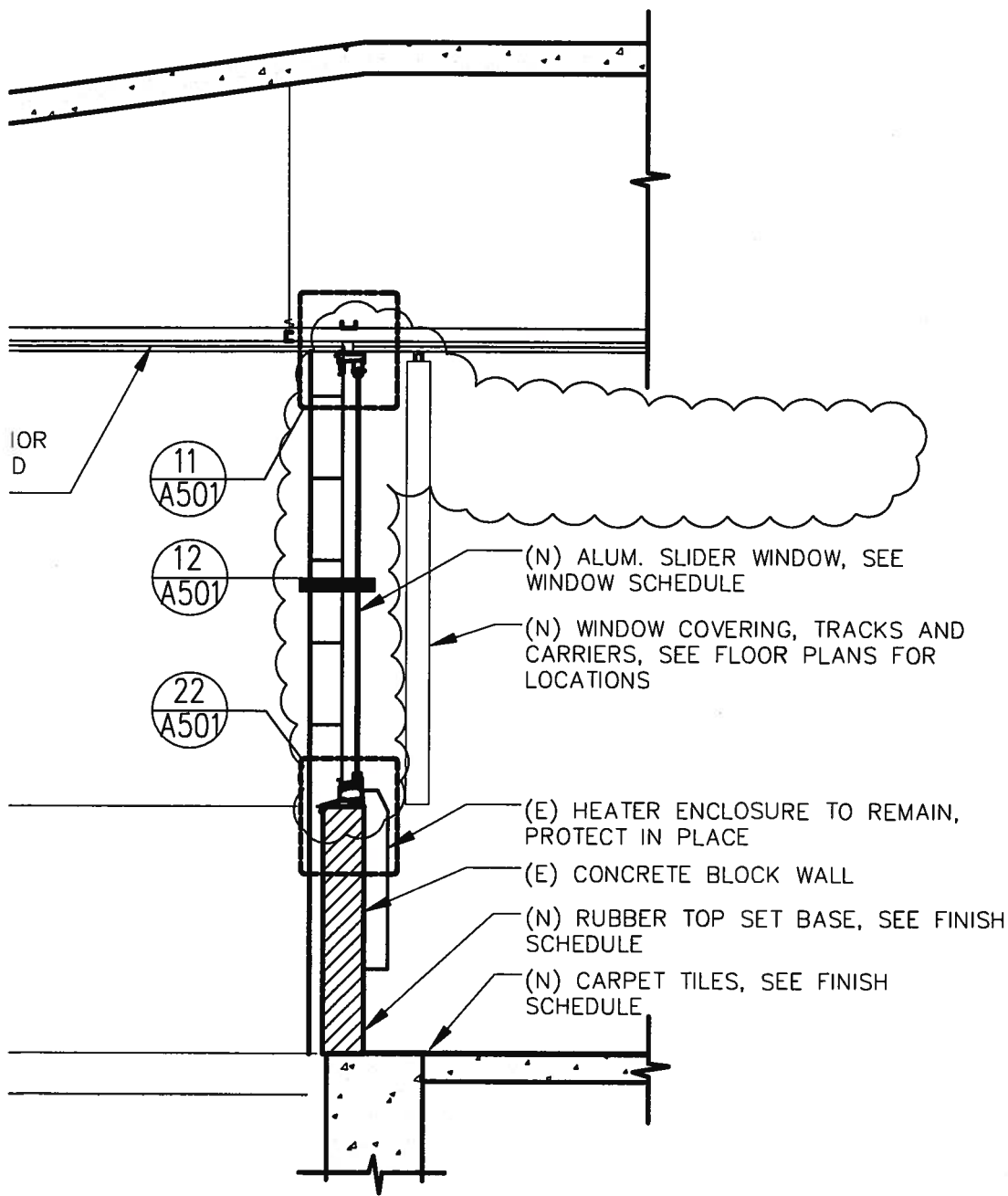

TYP. WALL SECTION AT R.D. SUITE

University of California Santa Barbara
 Anacapa Fire Safety and Renewal Building #547
 Santa Barbara CA 93106
 FM 130245L / 988650

WALL SECTION

SCALE: 1/4"=1'-0"

25
A302

UCSB DWG #	AD
547-114	2.1
DATE	
04/10/13	



RA
 RAVATT, ALBRECHT
 & ASSOCIATES
 3203 LIGHTNING STREET
 PO BOX 528
 SANTA MARIA CA 93456
 (805) 928-5002

These drawings are instruments of service and are the property of RA & Associates. The design and information represented on these drawings are exclusively for the project indicated and shall not be transferred or otherwise reproduced without express written permission of RA & Associates. Copyright 2013. Written dimensions take precedence over scaled dimensions. Do not scale plans. Contractor shall verify all dimensions and conditions in the field. Any discrepancies shall be called to the attention of RA & Associates.

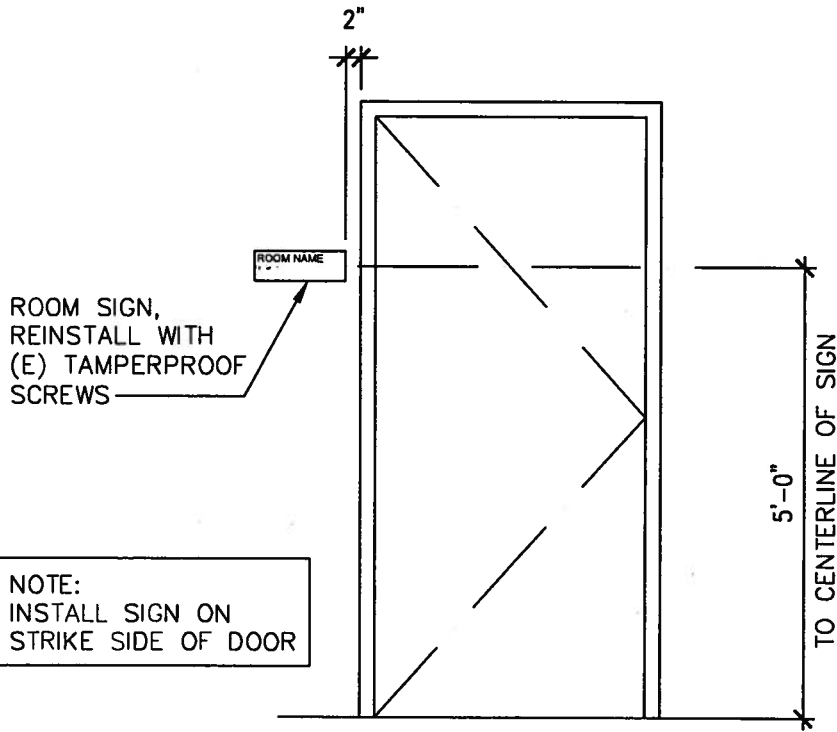

SIGNAGE MOUNTING

SCALE: 1/2" = 1'-0"

53
 A602

SIGNAGE MOUNTING

University of California Santa Barbara
 Anacapa Fire Safety and Renewal Building #547
 Santa Barbara CA 93106
 FM 130245L / 988650

UCSB DWG #
 547-114

DATE
 04/10/13

AD

2.12

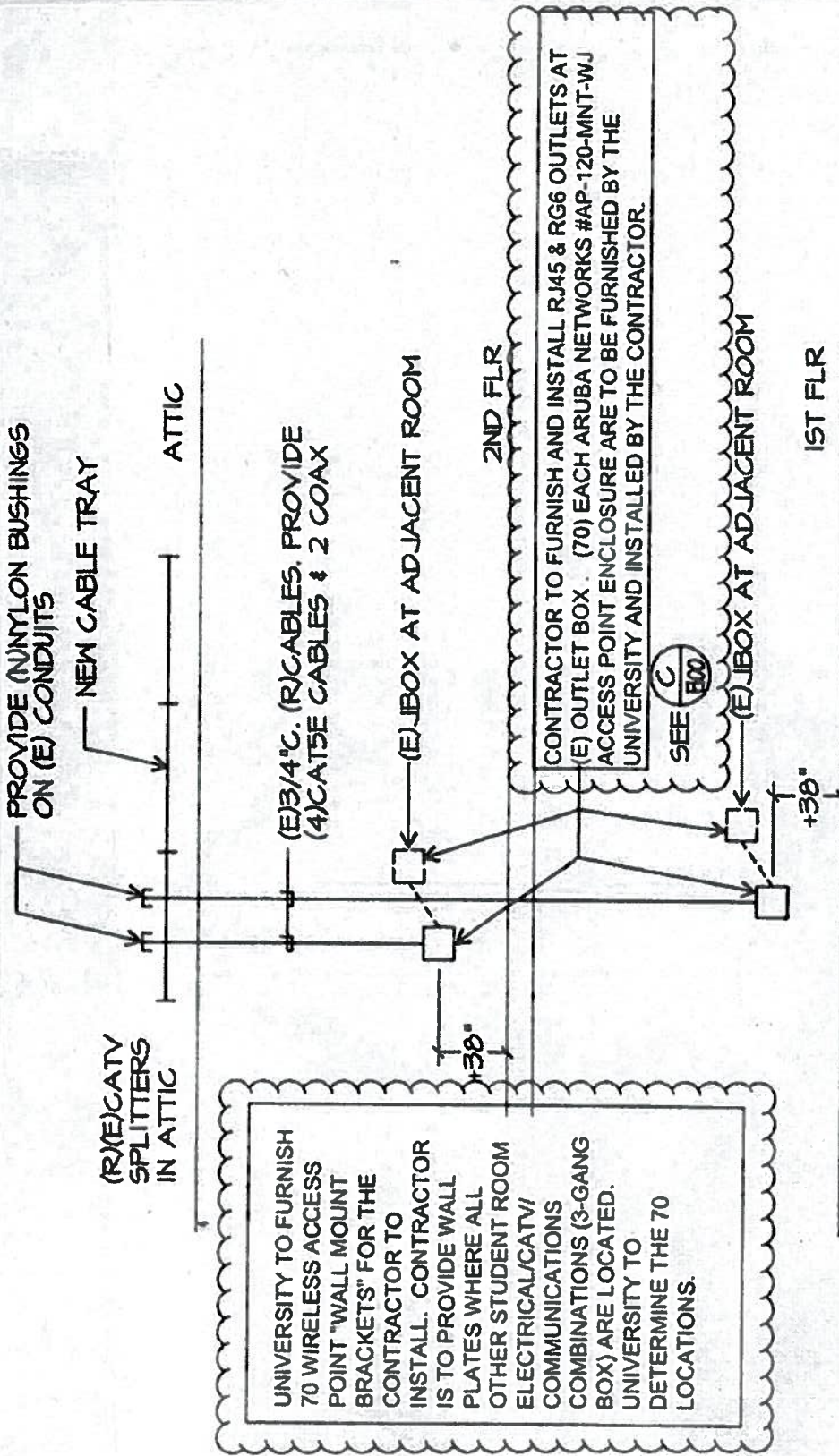

TYPICAL COMMUNICATIONS RISER

SHEET E100

SCALE: NONE

COMMUNICATIONS RISER

University of California Santa Barbara
 Anacapa Fire Safety and Renewal Building #547
 Santa Barbara CA 93106
 FM 130245L / 988650

UCSB DWG # 547-114	AD
DATE 04/10/13	2.13

These drawings are instruments of service and are the property of RA & Associates. The design and information represented on these drawings are exclusively for the project indicated and shall not be transferred or otherwise reproduced without express written permission of RA & Associates. Copyright 2013. All rights reserved. Take precedence over scaled dimensions. Do not scale plans. Contractor shall verify all dimensions and conditions in the field. Any discrepancies shall be called to the attention of RA & Associates.

RA
 RAVATT, ALBRECHT & ASSOCIATES
 3203 LIGHTNING STREET
 PO BOX 528
 SANTA MARIA CA 93456
 (805) 928-5002